

# PATENT SPECIFICATION



812,671

*Date of Application and filing Complete*

*Specification: May 24, 1957.*

*No. 16585/57*

*Application made in Italy on June 27, 1956*

*Complete Specification Published: April 29, 1959*

Index at Acceptance:—Class 87(1), B4(C3B:F1B:G1:G2:H1B).

International Classification:—E04c.

## COMPLETE SPECIFICATION

### A New or Improved Flooring

I, ROBERTO PIODI, an Italian citizen, of 12, via Porro, Turin, Italy, do hereby declare the invention, for which I pray that a patent may be granted to me, and the method by which it is to be performed, to be particularly described in and by the following statement:—

This invention relates to a flooring of the type comprising equal quadrangular members of rubber or similar material, which are provided with two tenons and two mortises for interengagement of their edges, and in which said tenons are provided on two adjacent edges and said mortises on the other adjacent edges and are of undercut shape in cross-section.

According to the invention each tenon has its one end flush with the bottom of the mortise provided in the edge of the member which intersects the edge carrying said tenon and its other end spaced from the corner of the member at which the two edges of the latter carrying its two tenons meet.

In order that this invention may more readily be understood and further features thereof appreciated, several embodiments of the same will now be described by way of example only, with reference to the accompanying drawings in which:—

Figure 1 is a plan view of one of the flooring members according to the invention;

Figure 2 is a view from below of a flooring member according to the invention;

Figure 3 is a sectional view on the line III-III of Figure 2;

Figure 4 is a plan view of a plurality of interconnected members;

Figure 5 is a sectional view on line V-V of Figure 4;

Figure 6 shows a modification of Figure 5 on an enlarged scale;

Figure 7 is a plan view of a modified member construction;

Figure 8 is a part cross-sectional view on an enlarged scale of two contiguous members according to Figure 7 ready for assembly;

Figure 9 is a cross-sectional view of a member on a middle horizontal plane at the corner of said member at which the ends of its mortises meet;

Figure 10 is a plan view of a plurality of assembled elements; and

Figure 11 is a plan view of a modified element construction.

Referring to the drawings, the improved flooring comprises rubber members of quadrangular, preferably rectangular or square, shape. The members are formed on two adjacent sides with an undercut tenon 2 and on their two other sides with slots or mortises 3 matching the tenons for interengagement of the members to form a continuous surface (Figure 4).

The upper portion or layer 1 of the member is made of hard wearing rubber withstanding the action of atmospheric agents, ultra-violet rays and ageing generally, whilst its lower portion or face 4, is made substantially thinner than the upper portion 1, preferably of softer, even spongy rubber in order to confer to the flooring a high adaptability to bearing surfaces which are not truly smooth and a satisfactory adherence thereto.

If desired, the lower portion can be made from an inexpensive rubber mix including a filler of cotton or other material for the sake of economy.

Grooves 5 can be cut at the base of the flooring member and these confine lugs 6 for the purpose of improving aeration of the lower flooring portion.

In the construction shown in Figure 6, the members are formed at their edges with top seatings accommodating strips 7 for sealing the joints.

The members can be of any colour and

Printed  
Price

even of different materials, provided they are similar in properties to rubber.

In the construction shown in Figure 7 the flooring is made of a plurality of rectangular rubber members 10 preferably made up of two rubber layers interconnected on moulding.

Each member is conveniently of a length twice its width. This special sizing of the individual members has been deliberately selected in view of the fact that, on cooling, the moulded rubber shrinks to varying extents in different directions, partly as a consequence of the direction of calendaring on the raw mix.

In fact, a member moulded in a square mould would on cooling become rectangular, which would entail considerable difficulties in distinguishing the larger from the smaller side in laying owing to the slight difference in size. Where the direction of calendaring of the raw rubber is not taken care of in placing it into the mould, the mortises and tenons might result arbitrarily on non-matching longer and shorter sides.

The rectangular form of the element fully avoids these drawbacks as it clearly distinguishes both on moulding and laying the longer side of the individual members without the need for a particular mark, whereby variations in size of the members, where the blanks have been all calendared in the same direction, are minimised.

As in the previously described constructions, the members 10 are formed with tenons 11 and 12 on two adjacent sides interchanging with the contiguous elements and with mortises 13, 14 in their remaining two sides.

Generally, with elements of the preferred rectangular form shown in Figure 7, the tenon on the longer side of one member is fitted into the mortise in the longer side of the adjacent member by relatively sliding the members in a longitudinal direction, interengagement of two adjacent members by their shorter sides being effected by snap action by a pressure directed perpendicularly to the joint line.

The tenons on the members are shaped in cross section to an arrow point 12A provided with a stem 12B connecting it to the edge of the member. The point 12A is slightly smaller in size than the mortise portion 13A adapted to receive it in the co-operating member. Moreover, the stem is of a length  $b$  slightly exceeding the length  $a$  of the co-operating mortise portion 13B. This particular sizing of the mortises and tenons was deliberately selected in order to facilitate snapping of the members into one another, which might fail if both mortises and tenons were made of the same size.

The surfaces of the member edge above and below the tenon, denoted by 15 in

Figure 8, forms, with a horizontal plane extending through the tenon, an angle  $c$  slightly less than  $90^\circ$  in order to ensure an exact contact of the edges of adjacent members.

It will be seen from Figure 7 that the tenons are slightly shorter in length than the edge of the member from which they extend.

As shown in Figure 9, which is a horizontal section view of a member at the region adjacent the corner 17 at which the mortises of said member meet, the ends of said mortises are closed, whereby the rubber-filled angle 10A is strengthened against yielding.

According to the construction shown in Figure 11 the tenons comprise projections such as 22A, 22B, 22C etc. and 21A, 21B, 21C etc. separated by gaps or recesses.

This structure is more particularly suitable for the shorter sides of the members which are assembled by snap action under pressure instead of by sliding the tenon along the mortise. The mortise may preferably be made continuous in the longer side and discontinuous in the shorter side of the member for the sake of assembly of the latter under pressure in a perpendicular direction between two members with respect to the edge to be connected as well as of a firm assembly against lateral displacements.

#### WHAT I CLAIM IS:

1. Flooring comprising equal quadrangular members of rubber or similar material, such members being provided with two tenons and two mortises for interengagement of their edges, said tenons being provided on two adjacent edges and said mortises on the other adjacent edges of each member and being of undercut shape in cross-section, wherein each tenon has its one end flush with the bottom of the mortise provided in the edge of the member intersecting the edge carrying said tenon and its other end spaced from the corner of the member at which the two edges of the latter carrying said two tenons meet.

2. Flooring according to Claim 1, wherein an upper portion of each member is made of hard-wear rubber, its lower portion being made of softer rubber, such as spongy rubber.

3. Flooring according to any of the preceding claims, wherein the members are formed on their lower faces with grooves for aeration purposes.

4. Flooring according to any of the preceding claims, wherein seatings are formed along the edges of the members for accommodating strips sealing the joints.

5. Flooring according to Claim 1, wherein the tenons on the members are shaped to an arrow-point, provided with a stem connecting with the edges of the member, said arrow-point being slightly smaller in size

70

75

80

85

90

95

100

105

110

115

120

125

130

812,671

3

- than the portion of the co-operating mortise in adjacent member, the stem slightly exceeding in length the portion of its co-operating mortise.
- 5 6. Flooring according to claim 5, wherein a portion of the edge of the member above and below the tenon is somewhat outwardly inclined towards the latter to provide accurate juxtaposition of the top edges of adjacent members.
- 10 7. Flooring according to claim 1, wherein the adjacent ends of the mortises in two adjacent edges of the same member are closed.
- 15 8. Flooring as claimed in claim 1, wherein the tenons are interrupted by gaps.
9. Flooring according to any of the preceding claims, wherein the members are rectangular in shape, their length being twice their width.
- 20 10. Flooring substantially as hereinbefore described with reference to and as shown by Figures 1 to 5 of the accompanying drawings.
11. Flooring according to claim 10, 25 modified substantially as hereinbefore described with reference to and as shown by Figure 6 of the accompanying drawings.
12. Flooring according to claim 10, 30 modified substantially as hereinbefore described with reference to and as shown by Figures 7, 8 and 10, or Figures 7, 9 and 10 of the accompanying drawings.
13. Flooring according to any of claims 10 to 12, modified substantially as herein- 35 before described with reference to and as shown by Figure 11 of the accompanying drawings.

FORRESTER, KETLEY & CO.,  
Chartered Patent Agents,  
Jessel Chambers, 88-90 Chancery Lane,  
London, W.C.2,  
and Central House, 75, New Street,  
Birmingham, 2.  
Agents for the Applicants.

Berwick-upon-Tweed: Printed for Her Majesty's Stationery Office, by The Tweeddale Press Ltd.—1959  
Published at The Patent Office, 25, Southampton Buildings, London, W.C.2., from which copies may  
be obtained.

*Fig. 1*

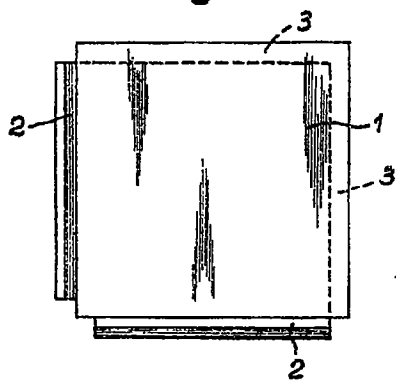

*Fig. 2*

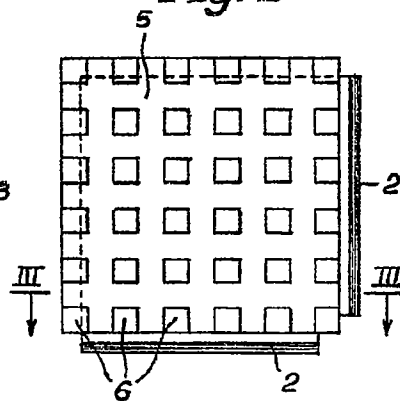

*Fig. 3*

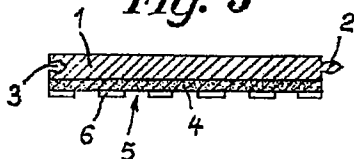

*Fig. 4*

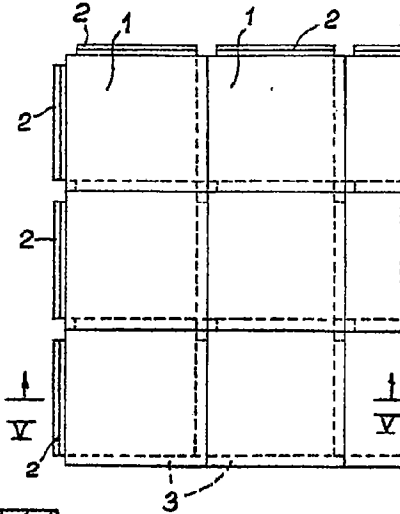

*Fig. 5*

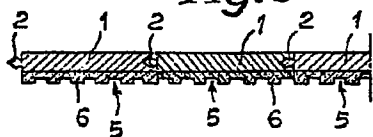

*Fig. 6*

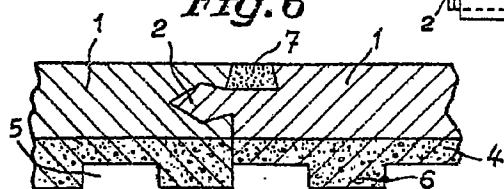

812,671 COMPLETE SPECIFICATION

2 SHEETS

This drawing is a reproduction of the Original on a reduced scale.

SHEETS 1 & 2

-2

III  
↓

IV  
↑

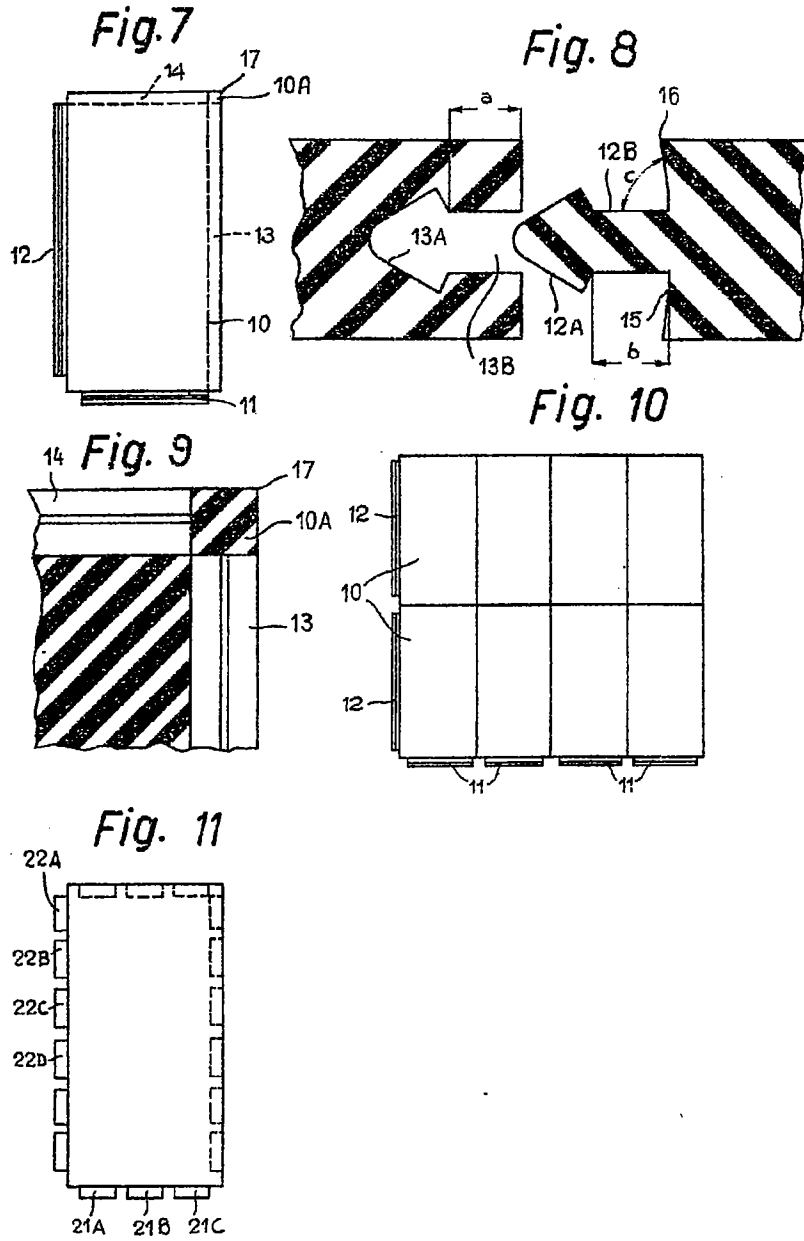

812,671 COMPLETE SPECIFICATION  
2 SHEETS  
This drawing is a reproduction of  
the Original on a reduced scale.  
SHEETS 1 & 2

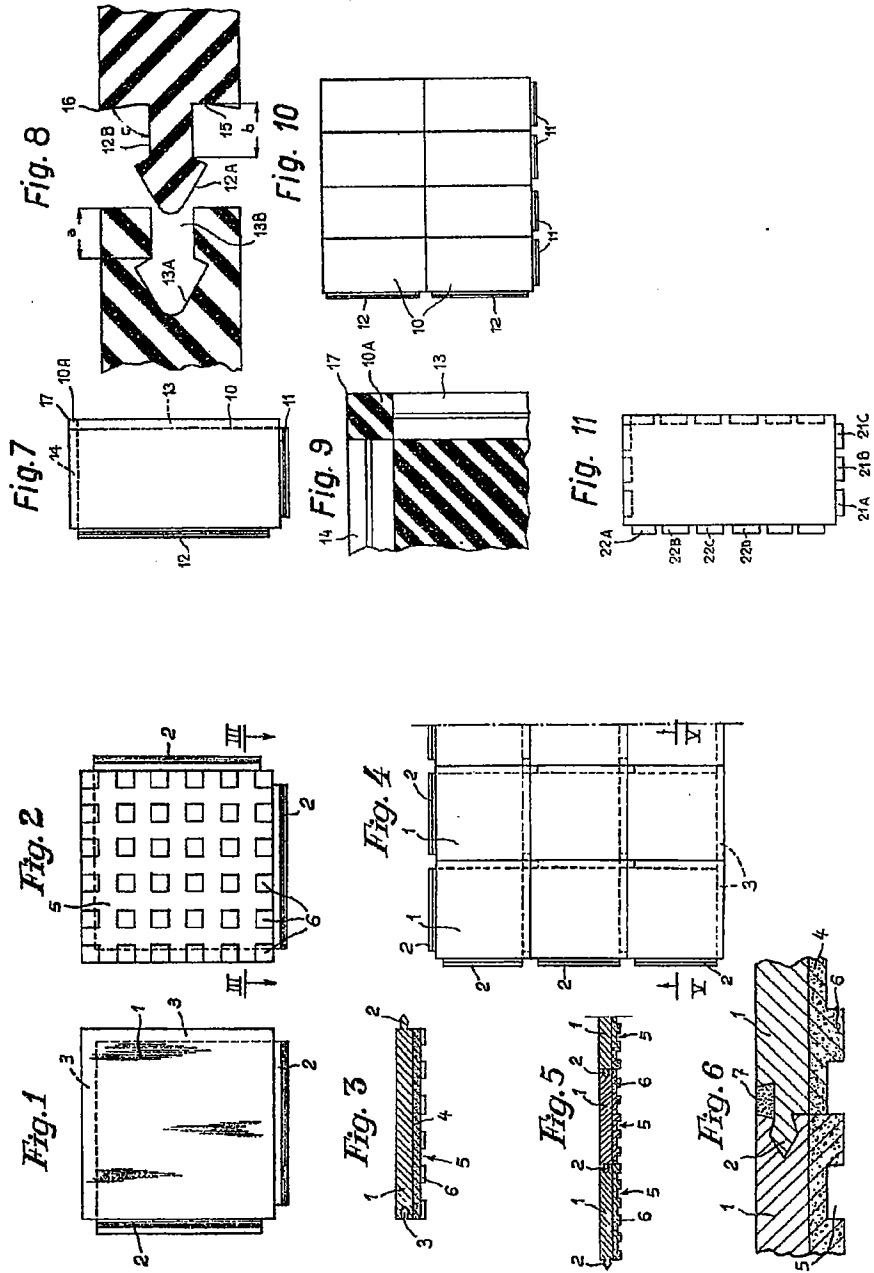

POOR QUALITY